

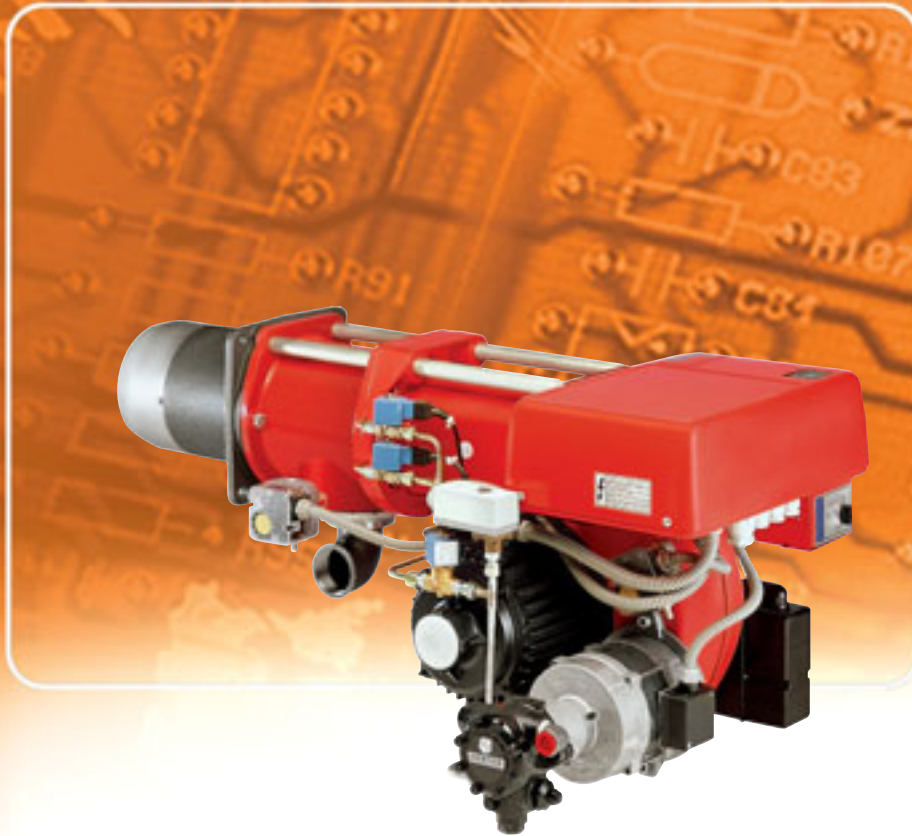

## TWO STAGE DUAL FUEL BURNERS

▶ <b>GI/EMME SERIES</b>	▶ <b>GI/EMME 300</b> 107/175+ 332 kW
	▶ <b>GI/EMME 400</b> 116/232+ 465 kW
	▶ <b>GI/EMME 600</b> 174/348+ 665 kW
	▶ <b>GI/EMME 900</b> 250/525+ 922 kW



The GI/EMME 300-900 series of burners covers a firing range from 107 to 922 kW. They have been designed for middle and high output users and they are in particular suitable for matching with pressurized boilers.

Their use allows to have a high safety in operation, guaranteed from the double fuel supply. Two options of operation are available: only gas and only light oil, thus settable by a selector and a terminal board. Light oil circuit is fitted with its own electric motor: this permits pump stop during gas operation preventing danger of pumping seizure. A wide range of accessories and gas trains suitable to the burners guarantee an elevated working flexibility.



## TECHNICAL DATA

Model			▼ GI/EMME 300	▼ GI/EMME 400	▼ GI/EMME 600	▼ GI/EMME 900
Burner operation mode			Two stage			
Modulating ratio at max. output			2:1			
Servomotor	type		LKS 210			
	run time	s	5			
Heat output	kW		107/175 - 332	116/232 - 465	174/348 - 665	250/525 - 922
	Mcal/h		92/150 - 286	100/200 - 400	150/299 - 572	215/452 - 793
Working temperature		°C min/max	0/40			
Oil	Net calorific value	kWh/kg	11,8			
	Viscosity	mm <sup>2</sup> /s ( cSt)	4-6 at 20°C			
	Delivery	kg/h	9/15 - 28	10/20 - 39	15/29 - 56	21/44 - 78
Pump	type		AN 67	AN 67	AN 77	AN 97
	delivery	kg/h	75 at 12 bar	75 at 12 bar	100 at 12 bar	120 at 12 bar
Atomised pressure		bar	12			
Fuel temperature		max °C	60			
Fuel preheater			NO			
G20	Net calorific value	kWh/Nm <sup>3</sup>	10			
	Density	kg/Nm <sup>3</sup>	0,71			
	Gas delivery	Nm <sup>3</sup> /h	10,7/17,5 - 33,2	11,6/23,2 - 46,5	17,4/34,8 - 66,5	25/52,5 - 92,2
G25	Net calorific value	kWh/Nm <sup>3</sup>	8,6			
	Density	kg/Nm <sup>3</sup>	0,78			
	Gas delivery	Nm <sup>3</sup> /h	12,4/20,3 - 38,6	13,5/27 - 54	20,2/40,4 - 77,3	29/61 - 107,2
LPG	Net calorific value	kWh/Nm <sup>3</sup>	25,8			
	Density	kg/Nm <sup>3</sup>	2,02			
	Gas delivery	Nm <sup>3</sup> /h	4,1/6,8 - 12,9	4,5/9 - 18	6,7/13,5 - 25,8	9,7/20,3 - 35,7
Fan		type	Centrifugal with forward curve blades			
Air temperature		max °C	60			
Electrical supply		Ph/Hz/V	1/50/230 (± 10%)		3N/50/230-400 (±10%)	
Auxiliary electrical supply		Ph/Hz/V	1/50/230 (±10%)			
Control box		type	LFL 1.333			
Total electrical power		kW	0,5	0,62	1,1	2
Auxiliary electrical power		kW	0,1	0,1	0,2	0,35
Heaters electrical power		kW	--			
Protection level		IP	44			
Pump motor electrical power		kW	0,15			
Rated pump motor current		A	1,4		2,85	
Pump motor start up current		A	3,2		6,5	
Pump motor protection level		IP	44			
Fan motor electrical power		kW	0,25	0,37	0,75	1,5
Rated fan motor current		A	1,85	2,9	2,85/1,65	6,55/3,15
Fan motor start up current		A	4,2	6,6	6,5/3,8	32,75/15,75
Fan motor protection level		IP	44			
Ignition transformer		type	--			
		V1 - V2	230 V - 1x8 kV			
		I1 - I2	1,8 A - 30 mA			
Operation			Intermittent (at least one stop every 24h)			
Sound pressure		dB(A)	69	74	82	84
Sound power		W	--			
Oil	CO emission	mg/kWh	< 30			
	Grade of smoke indicator	N° Bacharach	--			
	CxHy emission	mg/kWh	--			
	NOx emission	mg/kWh	< 200			
G20	CO emission	mg/kWh	< 60			
	NOx emission	mg/kWh	< 120			
Directive			89/336 - 73/23 EEC			
Conforming to			EN 267 - EN 676			
Certification			--			

### Reference conditions:

Temperature: 20°C - Pressure: 1013,5 mbar - Altitude: 100 m a.s.l.  
Noise measured at a distance of 1 meter.

Since the Company is constantly engaged in the production improvement, the aesthetic and dimensional features, the technical data, the equipment and the accessories can be changed.

This document contains confidential and proprietary information of RIELLO S.p.A. Unless authorised, this information shall not be divulged, nor duplicated in whole or in part.



## FIRING RATES

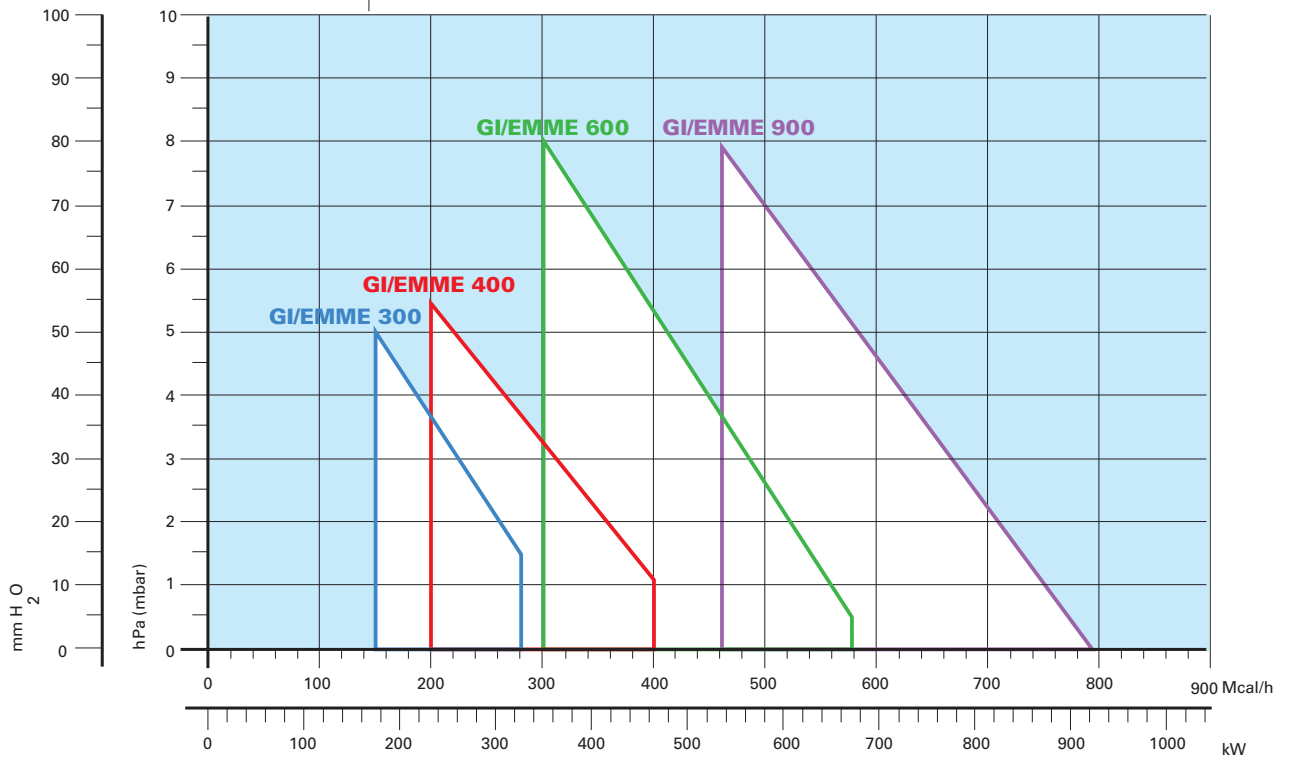

Useful working field for choosing the burner

**Test conditions conforming to EN 267 - EN 676:**

Temperature: 20°C  
Pressure: 1013.5 mbar  
Altitude: 100 m a.s.l.



# FUEL SUPPLY

## GASTRAIN



Example of gas inlet pipe burners for GI/EMME

The gas trains are fitted with a regulating valve to adjust fuel delivery in relation to heat required. This valve is controlled by the two-stages device fitted on the burner.

Fuel can be supplied either from the right or left sides, on the basis of the application requirements.

The gas train can be selected to best fit system requirements depending on the fuel output and pressure in the supply line. The gas trains can be "Multibloc" type (containing the main components in a single unit) or "Composed" type (assembly of the single components).

### MULTIBLOC gas train without seal control

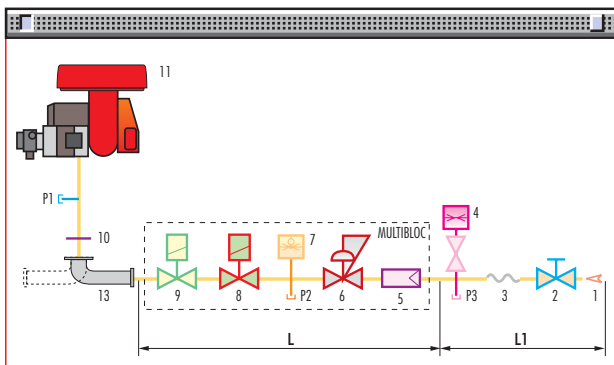

1	Gas input pipework
2	Manual valve
3	Anti-vibration joint
4	Pressure gauge with pushbutton cock
5	Filter
6	Pressure regulator (vertical)
7	Minimum gas pressure switch
8	VS safety solenoid (vertical)
9	VR regulation solenoid (vertical). Three adjustments: - 1 <sup>st</sup> stage delivery (rapid opening) - 1 <sup>st</sup> stage delivery (slow opening) - 2 <sup>nd</sup> stage delivery ((slow opening)
10	Gasket and flange supplied with the burner
11	Burner
12	Seal control mechanism for valves 8-9. According to standard EN 676, the seal control is compulsory for burners with maximum output above 1200 kW
13	Gas train-burner adapter.
P1	Combustion head pressure
P2	Pressure downstream from the regulator
P3	Pressure upstream from the filter
L	Gas train supplied separately, with the code given in the table
L1	Installer's responsibility

### MULTIBLOC gas train with seal control

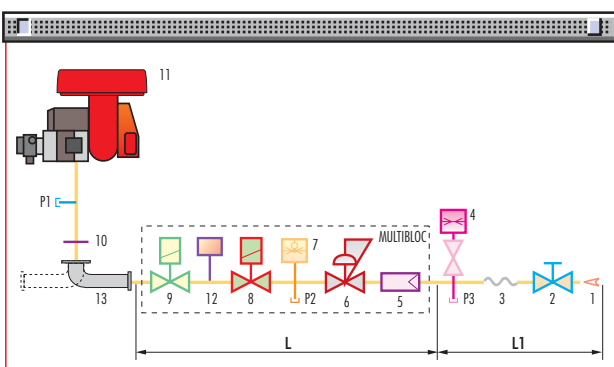

### COMPOSED gas train without seal control

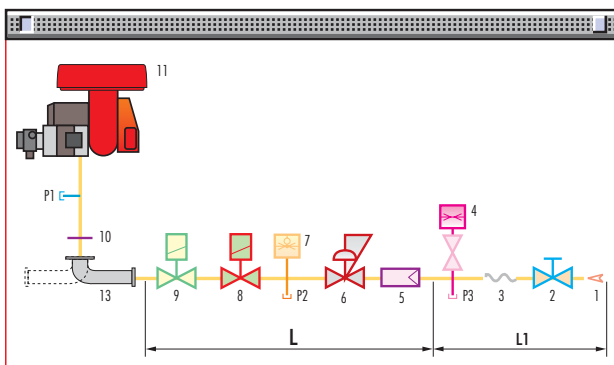

### COMPOSED gas train with seal control

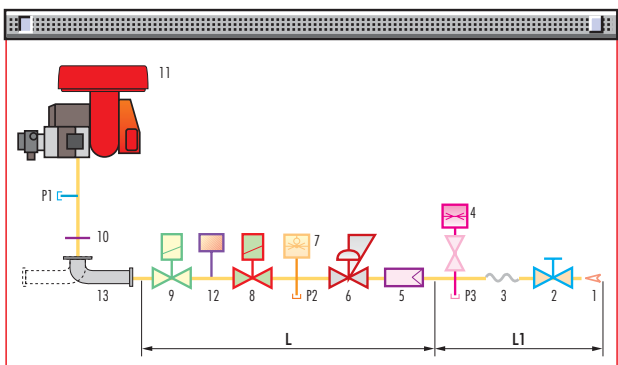

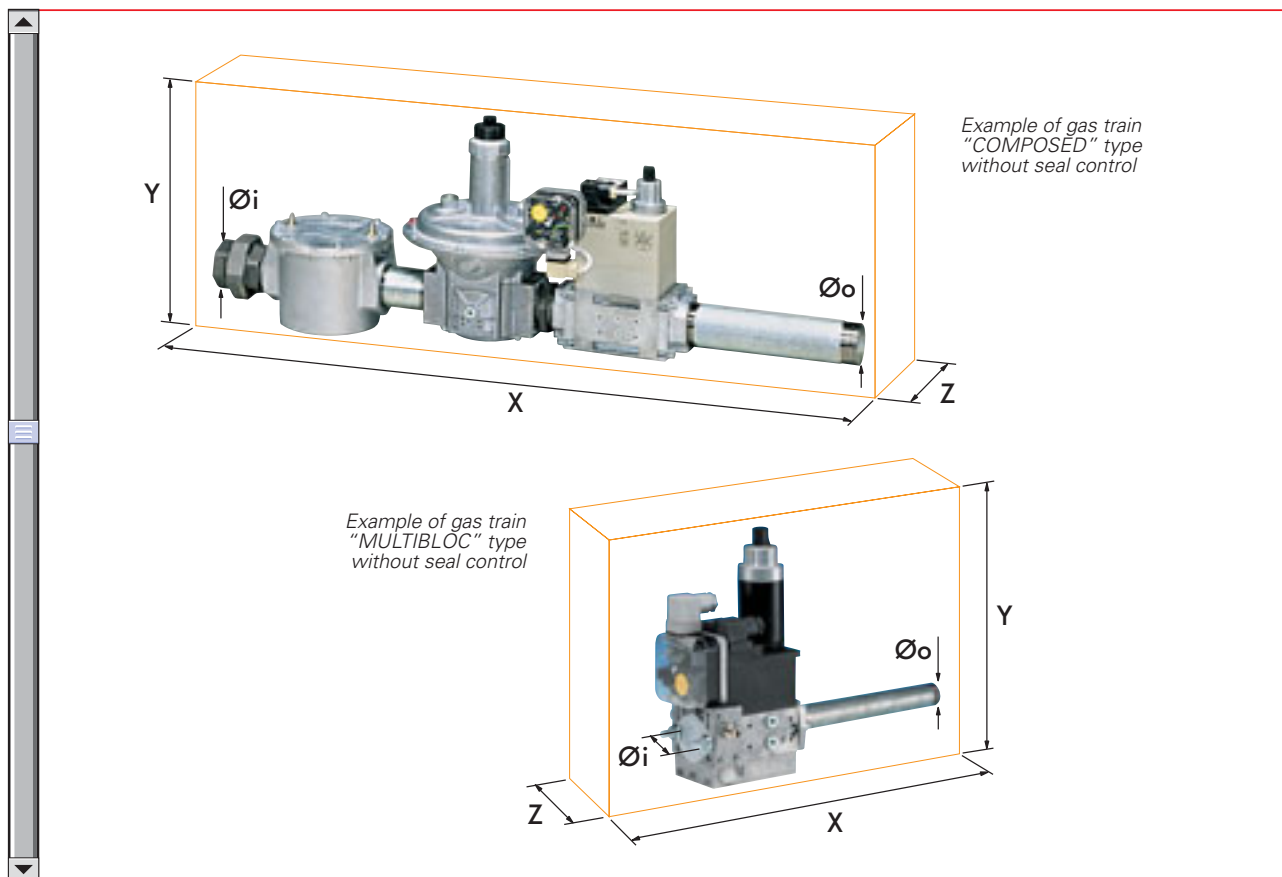

Gas trains are approved by standard EN 676 together with the burner.

The overall dimensions of the gas train depends on how they are constructed. The following table shows the maximum dimensions of the gas trains that can be fitted to RLS burners, intake and outlet diameters and seal control if fitted.

Please note that the seal control can be installed as an accessory, if not already installed on the gas train.

The maximum gas pressure of gas train "Multibloc" type is 300 mbar, and that one of gas train "Composed" type is 500 mbar.

	Name	Code	Ø i	Ø o	X mm	Y mm	Z mm	Seal Control
MULTIBLOC GAS TRAINS	MBZRDLE 407	3970556	3/4"	3/4"	195	235	120	-
	MBZRDLE 410	3970557	1"	3/4"	195	235	145	-
	MBZRDLE 412	3970152	1" 1/4	1" 1/2	433	290	145	-
	MBZRDLE 415	3970183	1" 1/2	1 21/2	523	346	100	-
	MBZRDLE 420	3970184	2"	2"	523	400	100	-
	MBZRDLE 420 CT	3970185	2"	2"	523	400	227	Incorporated
COMPOSED GAS TRAINS	CB 40/2	3970153	1" 1/2	1" 1/2	1013	346	195	-
	CB 50/2	3970154	2"	2"	1150	354	250	-
	CBF 65/2	3970155	DN 65	DN 65	1166	475	285	-
	CBF 65/2 CT	3970167	DN 65	DN 65	1166	475	285	Incorporated

## ► PRESSURE DROP DIAGRAM

The diagrams indicate the minimum pressure drop of the burners with the various gas trains that can be matched with them; at the value of these pressure drop add the combustion chamber pressure.

The value thus calculated represents the minimum required input pressure to the gas train.

### NATURAL GAS

#### GI/EMME 300

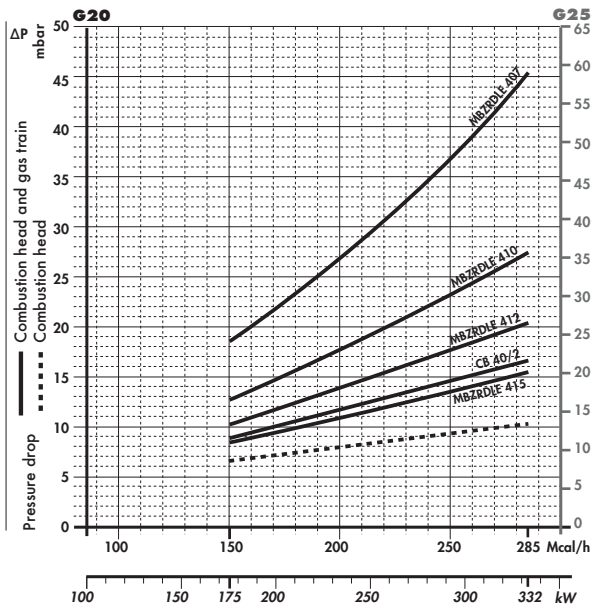

Gas train	Code	Adapter	Seal Control
MBZRDLE 407	3970556	3000824	Accessory
MBZRDLE 410	3970557	3000824	Accessory
MBZRDLE 412	3970152	3010124	Accessory

### LPG

#### GI/EMME 300

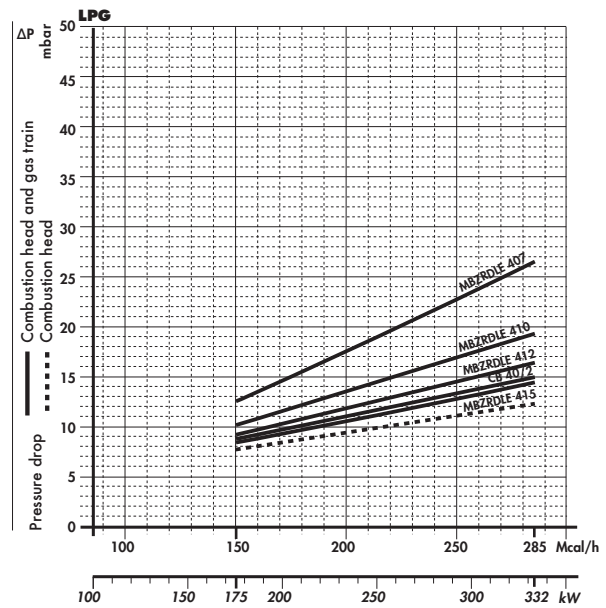

Gas train	Code	Adapter	Seal Control
MBZRDLE 415	3970183	-	Accessory
CB 40/2	3970153	-	Accessory

#### GI/EMME 400

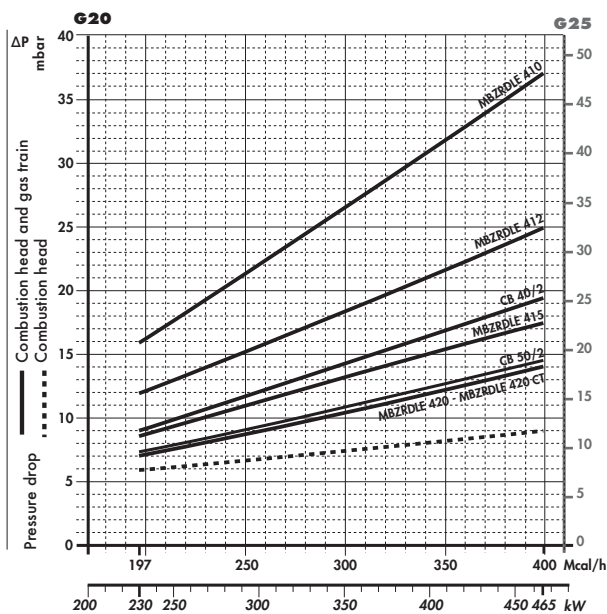

Gas train	Code	Adapter	Seal Control
MBZRDLE 410	3970557	3000824	Accessory
MBZRDLE 412	3970152	3010124	Accessory
MBZRDLE 415	3970183	-	Accessory
CB 40/2	3970153	-	Accessory

#### GI/EMME 400

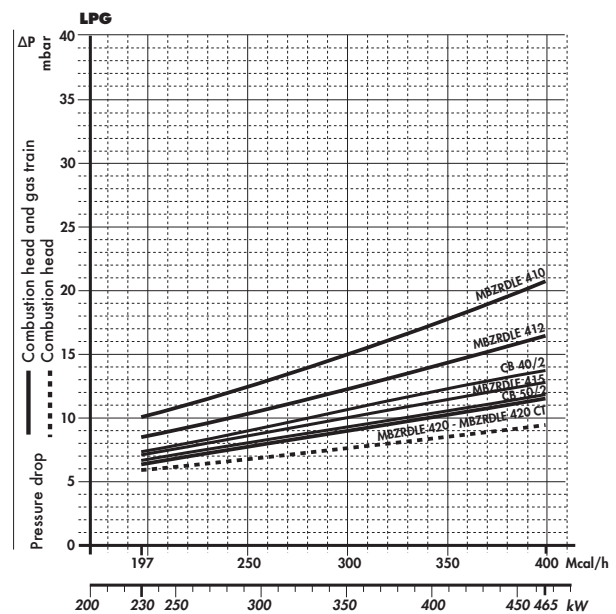

Gas train	Code	Adapter	Seal Control
CB 50/2	3970154	3000822	Accessory
MBZRDLE 420	3970184	3000822	Accessory
MBZRDLE 420 CT	3970185	3000822	Incorporated



## NATURAL GAS

## LPG

### GI/EMME 600

### GI/EMME 600

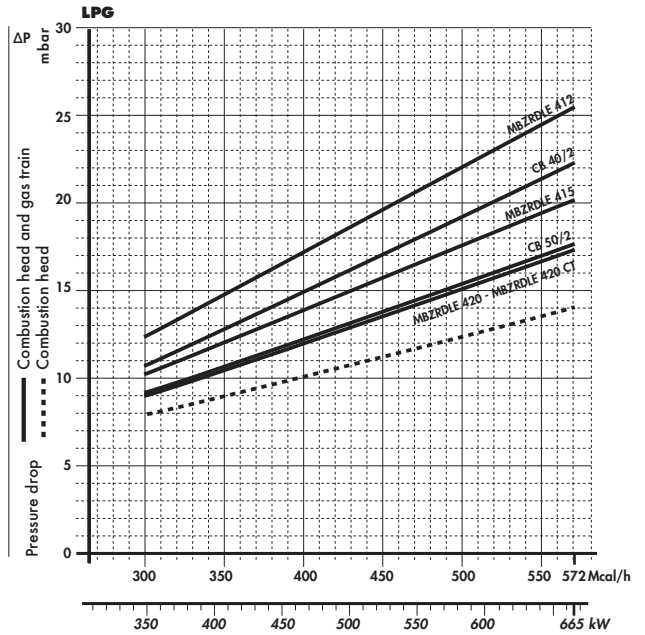
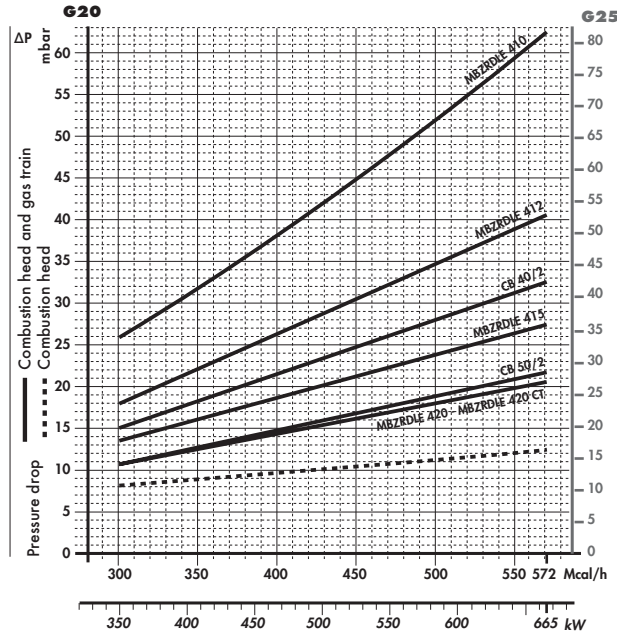

Gas train	Code	Adapter	Seal Control
MBZRDLE 410	3970557	3000824	Accessory
MBZRDLE 412	3970152	3010124	Accessory
MBZRDLE 415	3970183	-	Accessory
CB 40/2	3970153	-	Accessory

Gas train	Code	Adapter	Seal Control
CB 50/2	3970154	3000822	Accessory
MBZRDLE 420	3970184	3000822	Accessory
MBZRDLE 420 CT	3970185	3000822	Incorporated

### GI/EMME 900

### GI/EMME 900

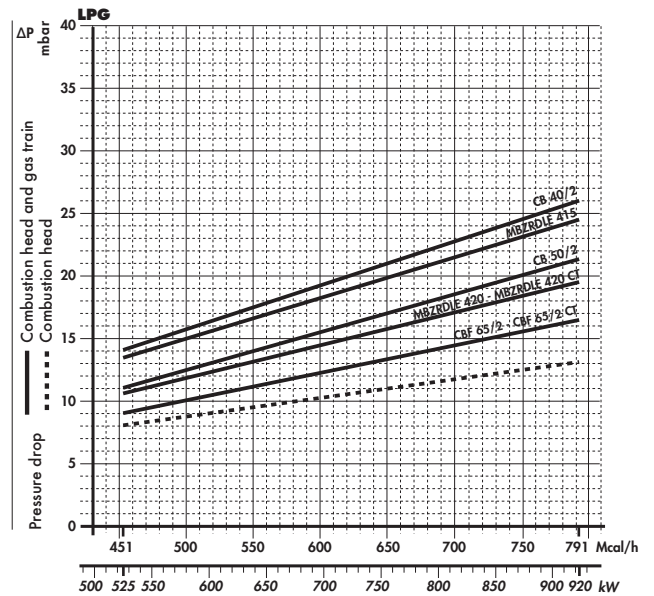
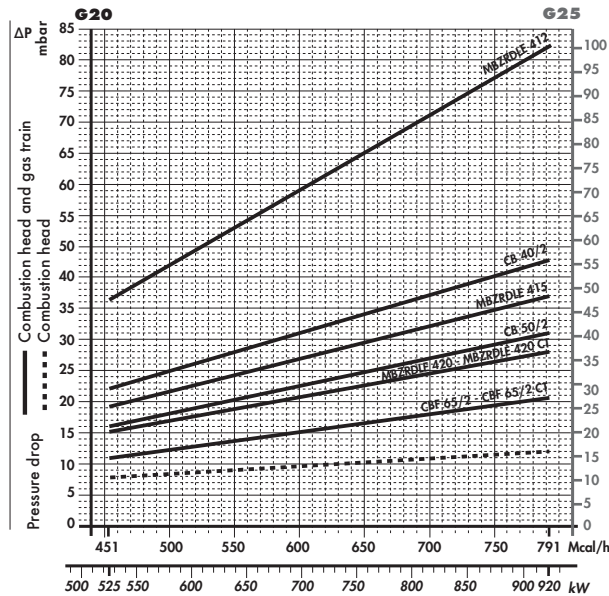

Gas train	Code	Adapter	Seal Control
MBZRDLE 412	3970152	3010126	Accessory
CB 40/2	3970153	3000843	Accessory
MBZRDLE 415	3970183	3000843	Accessory
MBZRDLE 420	3970184	-	Accessory

Gas train	Code	Adapter	Seal Control
MBZRDLE 420 CT	3970185	-	Incorporated
CB 50/2	3970154	-	Accessory
CBF 65/2	3970155	3000825	Accessory
CBF 65/2 CT	3970167	3000825	Incorporated

**note** Please contact the Riello Burner Technical Office for different pressure levels from those above indicated.





## SELECTING THE FUEL SUPPLY LINES

The following diagram enables pressure drop in a pre-existing gas line to be calculated and to select the correct gas train.

The diagram can also be used to select a new gas line when fuel output and pipe length are known. The pipe diameter is selected on the basis of the desired pressure drop. The diagram uses methane gas as reference; if another gas is used, conversion coefficient and a simple formula (on the diagram) transform the gas output to a methane equivalent (refer to figure A). Please note that the gas train dimensions must take into account the back pressure of the combustion chamber during operations.

### Control of the pressure drop in an existing gas line or selecting a new gas supply line.

The methane output equivalent is determined by the formula fig. A on the diagram and the conversion coefficient.

Once the equivalent output has been determined on the delivery scale ( $\dot{V}$ ), shown at the top of the diagram, move vertically downwards until you cross the line that represents the pipe diameter; at this point, move horizontally to the left until you meet the line that represents the pipe length.

Once this point is established you can verify, by moving vertically downwards, the pipe pressure drop of on the bottom scale below (mbar).

By subtracting this value from the pressure measured on the gas meter, the correct pressure value will be found for the choice of gas train.

- Example:**
- gas used G25
  - gas output 9.51 mc/h
  - pressure at the gas meter 20 mbar
  - gas line length 15 m
  - conversion coefficient 0.62 (see figure A)

- equivalent methane output  $\dot{V} = \left[ \frac{9.51}{0.62} \right] = 15.34 \text{ mc/h}$

- once the value of 15.34 has been identified on the output scale ( $\dot{V}$ ), moving vertically downwards you cross the line that represents 1" 1/4 (the chosen diameter for the piping);
- from this point, move horizontally to the left until you meet the line that represents the length of 15 m of the piping;
- move vertically downwards to determine a value of 1.4 mbar in the pressure drop bottom scale;
- subtract the determined pressure drop from the meter pressure, the correct pressure level will be found for the choice of gas train;
- correct pressure = ( 20-1.4 ) = 18.6 mbar

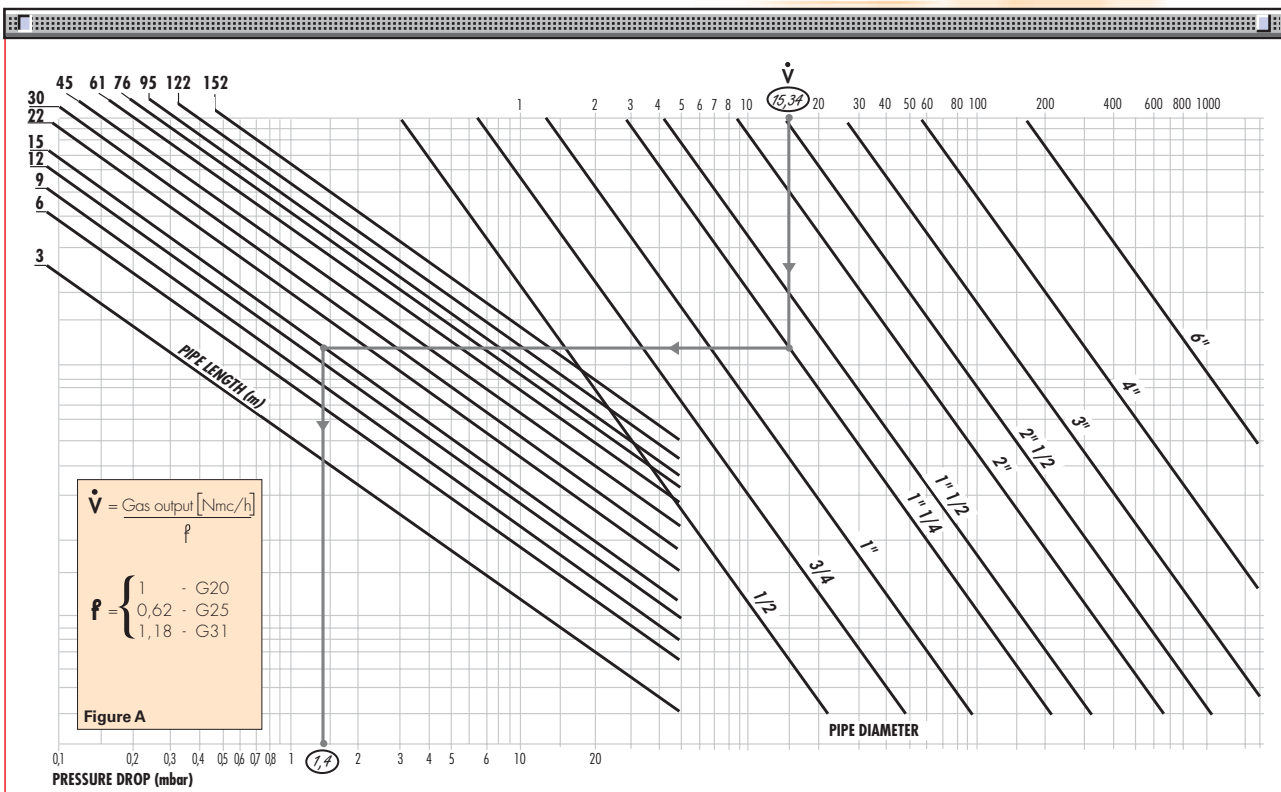



## ► HYDRAULIC CIRCUIT

The burners are fitted with three valves (a safety valve and two oil delivery valves) along the oil line from the pump to the nozzle. A thermostatic control device, on the basis of required output, regulates oil delivery valves opening, allowing light oil passage through the valves and to the nozzle.

Delivery valves open contemporary to the air damper opening, controlled by a servomotor.

The pumping group is fitted with a pump, an oil filter and a regulating valve: through this it is possible to manually adjust atomised pressure, which in factory is preset at 12 bar.



Example of light oil pump of GI/EMME burners

### GI/EMME 300 - 400 - 600 - 900

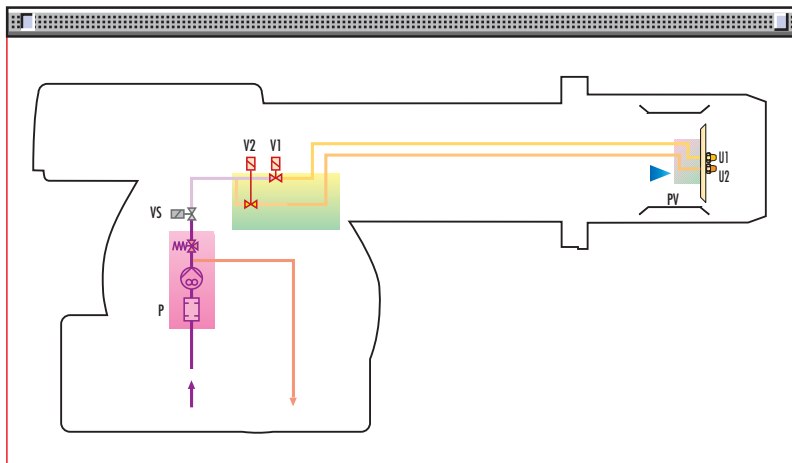

P	Pump with filter and pressure regulator on the output circuit
VS	Safety valve on the output circuit
V1	1st stage valve
V2	2nd stage valve
PV	Nozzle holder
U1	1st stage nozzle
U2	2nd stage nozzle



## SELECTING THE FUEL SUPPLY LINES

The fuel feed must be completed with the safety devices required by the local norms.

The table shows the choice of piping diameter for the various burners, depending on the difference in height between the burner and the tank and their distance.

MAXIMUM EQUIVALENT LENGTH FOR THE PIPING L[m]								
Model	GI/EMME 300		GI/EMME 400		GI/EMME 600		GI/EMME 900	
Piping diameter	8 mm	10 mm	8 mm	10 mm	10 mm	12 mm	12 mm	14 mm
+H, -H (m)	Lmax (m)	Lmax (m)	Lmax (m)	Lmax (m)	Lmax (m)	Lmax (m)	Lmax (m)	Lmax (m)
+4	33	83	20	51	51	112	71	138
+3	22	55	18	46	46	99	62	122
+4	19	48	16	39	39	86	58	106
+1,5	18	44	14	35	35	79	51	98
+1	16	40	13	32	32	73	44	90
+0,5	15	37	12	29	29	65	40	82
0	13	33	10	26	26	60	36	74
-0,5	12	29	9	23	23	54	32	66
-1	10	25	8	20	20	47	28	56
-1,5	8	21	6	16	16	40	23	49
-2	7	17	5	13	13	34	19	42
-3	4	10	3	7	7	21	190	26
-4	2	4	1	2	2	8	3	10

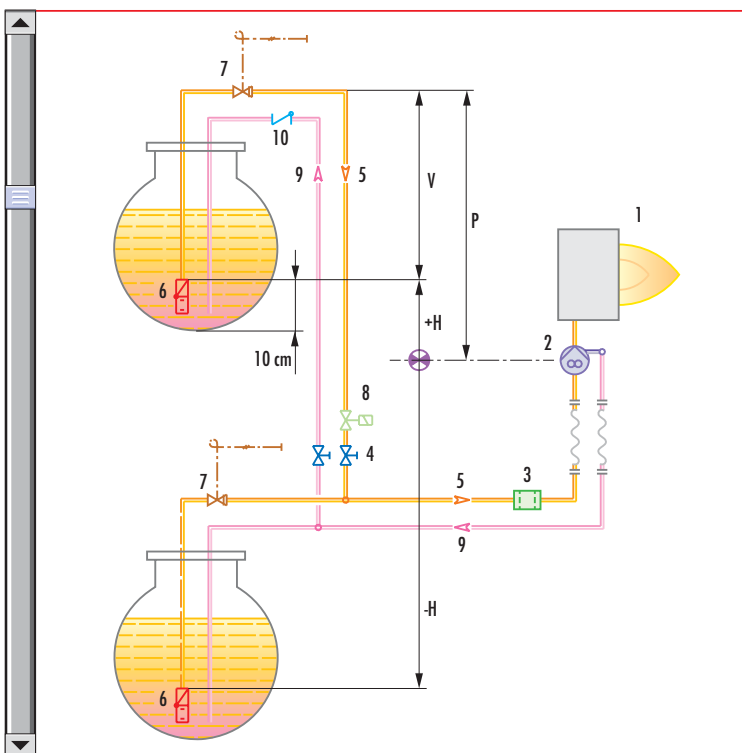

H	Difference in height pump-foot valve
Ø	Internal pipe diameter
P	Height ≤ 10 m
V	Height ≤ 4 m
1	Burner
2	Burner pump
3	Filter
4	Manual shut off valve
5	Suction pipework
6	Bottom valve
7	Remote controlled rapid manual shutoff valve (compulsory in Italy)
8	Type approved shut off solenoid (compulsory in Italy)
9	Return pipework
10	Check valve

**note** With ring distribution oil systems, the feasible drawings and dimensioning are the responsibility of specialised engineering studios, who must check compatibility with the requirements and features of each single installation.

## VENTILATION



Example of air damper of GI/EMME burners

The ventilation circuit comes with a forward blades centrifugal fan, which guarantees high pressure levels at the required air deliveries and permits installation flexibility.

In spite of the remarkable output power and of the very high pressure performance, GI/EMME models are extremely compact.

A minimum air pressure switch stops the burner when there is an insufficient quantity of air at the combustion head.

A servomotor allows to have a right air flow in any operational state and the closure of air damper when burner is in stand-by.



## COMBUSTION HEAD



Example of GI/EMME burners combustion head

Different lengths of the combustion head can be supplied (with application of a specific "extended head kit") for the GI/EMME series of burners.

The choice depends on the thickness of the front panel and type of boiler.

Correct head penetration into the combustion chamber depends on the type of heat generator.

The following diagram shows the flame dimensions in relation to the burner output. The lengths and diameter shown in the diagram below should be employed for a preliminary check: if the combustion chamber dimensions are different from the values in the diagram, further tests need to be done.



### Flame dimensions

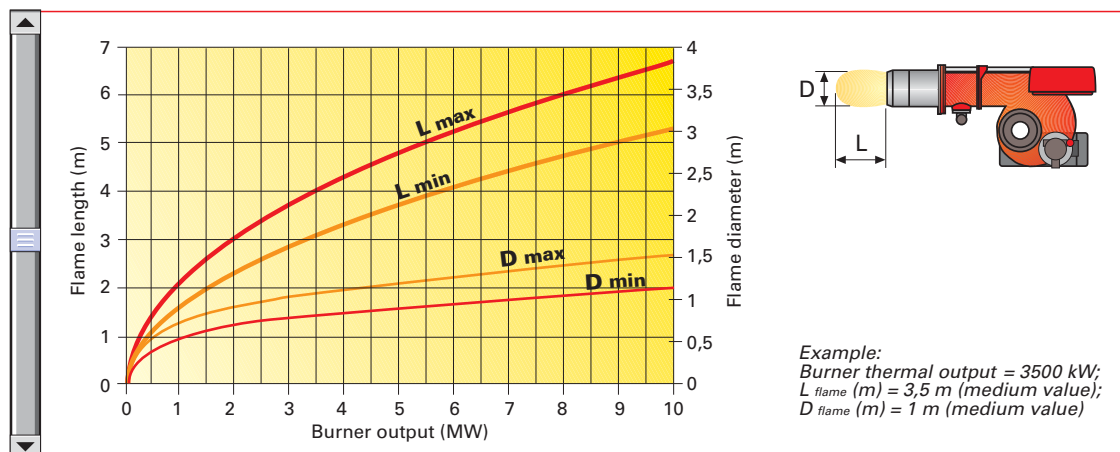



## ADJUSTMENT

### BURNER OPERATION MODE

With two stage operation, the GI/EMME series of burners can follow the temperature load requested by the system. A modulation ratio of 2:1 is reached thanks to the nozzles when burner is supplied with light oil and to the two-stage gas train when burner is supplied from gas; the air is adapted to the servomotor rotations.

On "two stage" operation, the burner gradually adjusts output to the requested level, by varying between two pre-set levels (see picture A).

#### Two stage operation

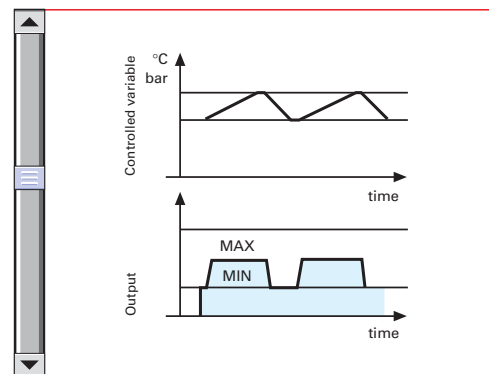

Picture A

### START UP CYCLE

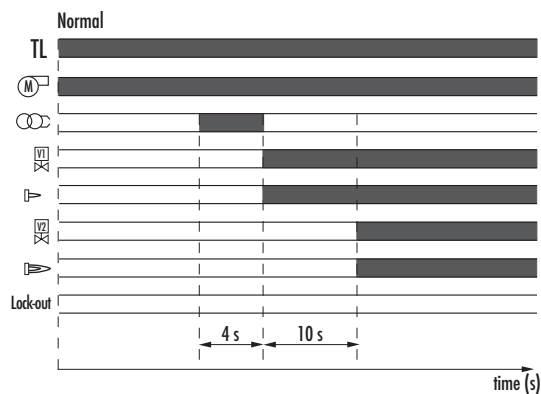

- 0" Thermostat closes. The motor starts running.
- 36" Pre-ignition (\*)
- 40" 1<sup>st</sup> stage valve opens; 1<sup>st</sup> stage flame (\*\*).
- 50" If heat request is not yet satisfied, 2<sup>nd</sup> stage solenoid valve opens. The start up cycle comes to an end. 2<sup>nd</sup> stage flame (\*\*\*)

(\*) 49" for GI/EMME 300.  
 (\*\*) 55" for GI/EMME 300.  
 (\*\*\*) 67" for GI/EMME 300.

# WIRING DIAGRAMS



Electrical connections must be made by qualified and skilled personnel, according to the local norms.

## TWO STAGE OPERATION

**GI/EMME 300-400  
Without seal control**

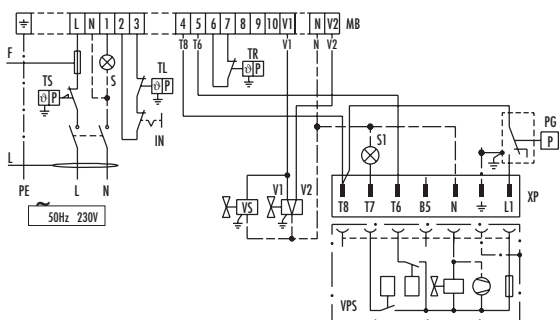

- MB** - Burner terminal board
- IN** - Burner manual stop switch
- PG** - Min. gas pressure switch
- S** - Remote lock-out signal
- TL** - Load limit remote control system
- TR** - High-Low mode remote control system
- TS** - Safety load control system
- V1** - Regulating valve 1<sup>st</sup> stage
- V2** - Regulating valve 2<sup>nd</sup> stage
- VS** - Safety valve

**GI/EMME 600-900  
Without seal control**

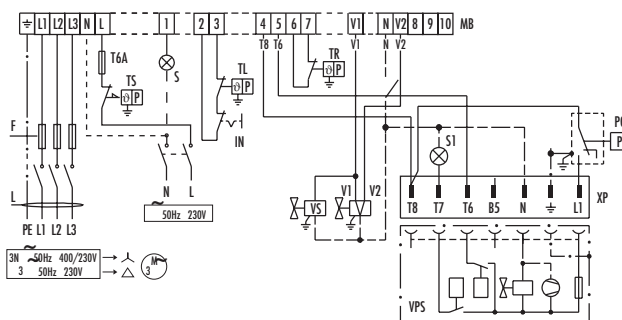

- MB** - Burner terminal board
- IN** - Burner manual stop switch
- PG** - Min. gas pressure switch
- S** - Remote lock-out signal
- TL** - Load limit remote control system
- TR** - High-Low mode remote control system
- TS** - Safety load control system
- V1** - Regulating valve 1<sup>st</sup> stage
- V2** - Regulating valve 2<sup>nd</sup> stage
- VS** - Safety valve

**GI/EMME 300-400  
With seal control**

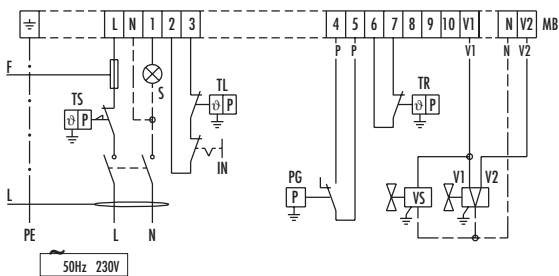

- MB** - Burner terminal board
- IN** - Burner manual stop switch
- PG** - Min. gas pressure switch
- S** - Remote lock-out signal
- S1** - Remote lock-out signal of seal control device
- TL** - Load limit remote control system
- TR** - High-Low mode remote control system
- TS** - Safety load control system
- VPS** - Seal control device
- V1** - Regulating valve 1<sup>st</sup> stage
- V2** - Regulating valve 2<sup>nd</sup> stage
- VS** - Safety valve
- XP** - Plug for seal control device

**GI/EMME 600-900  
With seal control**

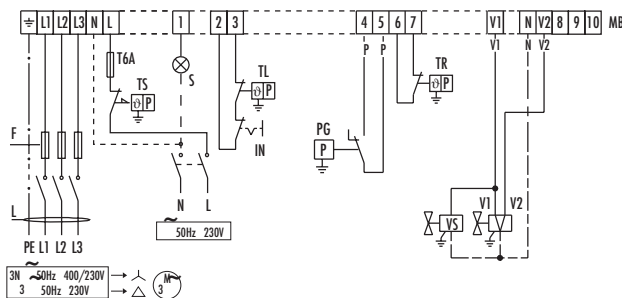

- MB** - Burner terminal board
- IN** - Burner manual stop switch
- PG** - Min. gas pressure switch
- S** - Remote lock-out signal
- S1** - Remote lock-out signal of seal control device
- TL** - Load limit remote control system
- TR** - High-Low mode remote control system
- TS** - Safety load control system
- VPS** - Seal control device
- V1** - Regulating valve 1<sup>st</sup> stage
- V2** - Regulating valve 2<sup>nd</sup> stage
- VS** - Safety valve
- XP** - Plug for seal control device

The following table shows the supply lead sections and the type of fuse to be used.

Model	GI/EMME 300	GI/EMME 400	GI/EMME 600	GI/EMME 900
	230V	230V	230V	400V
F A	T6	T6	T6	T16
L mm <sup>2</sup>	1,5	1,5	1,5	1,5





## EMISSIONS

### NO<sub>x</sub> EMISSIONS

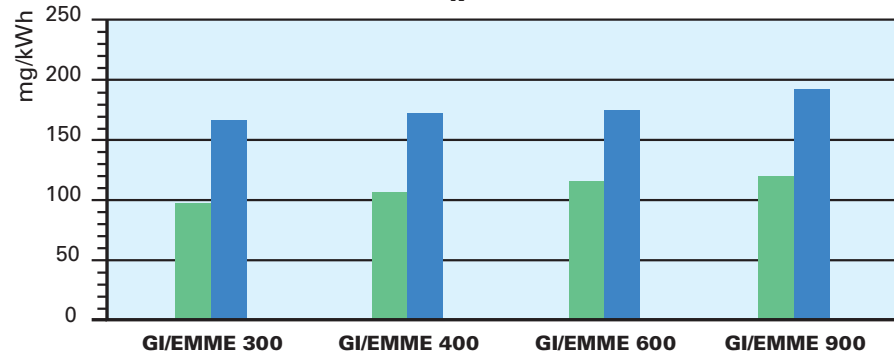

- Gas working
- Light oil working

### CO EMISSIONS

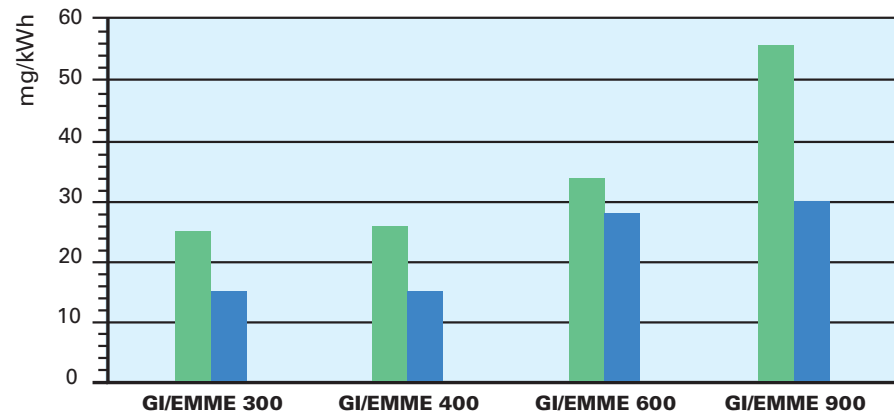

### NOISE EMISSIONS

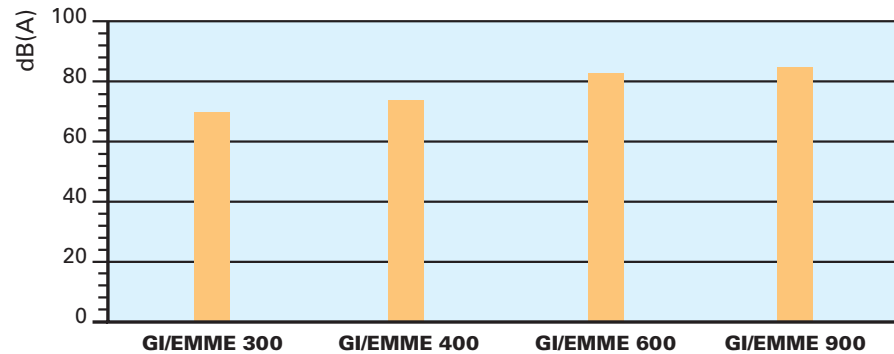

The emission data has been measured in the various models at maximum output, according to EN 676 and EN 267 standard.

## OVERALL DIMENSIONS (mm)



### BURNER

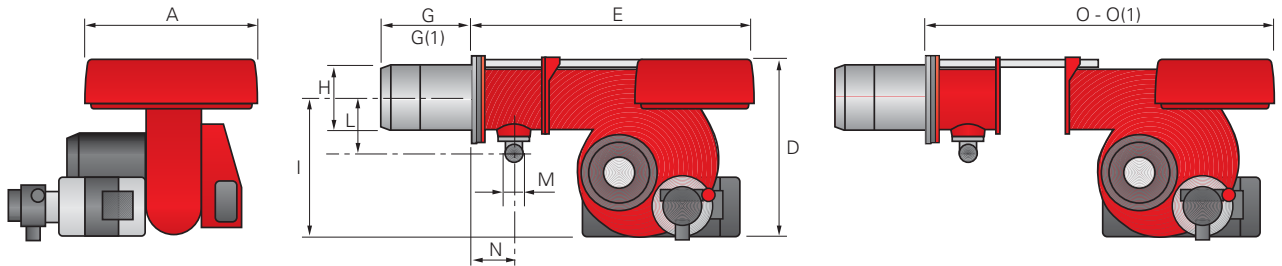

Model	A	E	G	G(1)	D	H	L	M	I	N	O	O(1)
▶ GI/EMME 300	410	610	185	320	397	140	165	1"1/2	292	97	978	978
▶ GI/EMME 400	410	610	187	320	397	150	165	1"1/2	292	97	1018	1018
▶ GI/EMME 600	410	645	187	320	437	155	165	1"1/2	332	97	1063	1063
▶ GI/EMME 900	410	770	227	360	485	175	195	2"	370	131	1260	1260

(1) Dimension with "extended head".

### BURNER - BOILER MOUNTING FLANGE

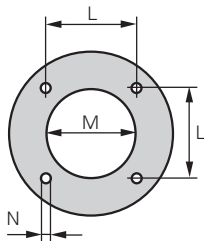

Model	L	M	N
▶ GI/EMME 300	160	155	M 10
▶ GI/EMME 400	160	165	M 10
▶ GI/EMME 600	160	165	M 10
▶ GI/EMME 900	195	185	M 12

### PACKAGING

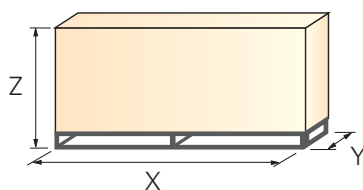

Model	X	Y	Z	kg
▶ GI/EMME 300	835	530	453	42
▶ GI/EMME 400	835	530	453	49
▶ GI/EMME 600	880	530	500	64
▶ GI/EMME 900	103	530	435	88



## INSTALLATION DESCRIPTION

Installation, start up and maintenance must be carried out by qualified and skilled personnel. All operations must be performed in accordance with the technical handbook supplied with the burner.

### ► BURNER SETTING

- ▶ All the burners have slide bars, for easier installation and maintenance.
- ▶ After drilling the boilerplate, using the supplied gasket as a template, dismantle the blast tube from the burner and fix it to the boiler.
- ▶ Adjust the combustion head.
- ▶ Fit the gas train choosing this on the basis of the maximum boiler output and following the diagrams included in the burner instruction handbook
- ▶ Refit the burner casing to the slide bars.
- ▶ Install the nozzle choosing this on the basis of the maximum boiler output and following the diagrams included in the burner instruction handbook.
- ▶ Check the position of the electrodes.
- ▶ Close the burner, sliding it up to the flange, keeping it slightly raised to avoid the flame stability disk rubbing against the blast tube.

### ► ELECTRICAL AND HYDRAULIC CONNECTIONS AND START UP

- ▶ The burners are supplied for connection to two pipes fuel supply system.
- ▶ Connect the ends of the flexible pipes to the suction and return pipework using the supplied nipples.
- ▶ Make the electrical connections to the burner following the wiring diagrams included in the instruction handbook.
- ▶ Prime the pump by turning the motor (after checking rotation direction if it is a three phase motor).
- ▶ Adjust the gas train for start-up  
On start-up, check:  
Pressure pump and valve unit regulator (to max. and min.)  
Gas pressure at the combustion head (to max. and min. output)  
Combustion quality, in terms of unburned substances and excess air.

## BURNER ACCESSORIES



### Nozzles

The nozzles must be ordered separately. The following table shows the features and codes on the basis of the maximum required fuel delivery.



Nozzles type 60° B			
Burner	GPH	Rated delivery (kg/h) at 12 bar	Nozzle code
GI/EMME 300	1,75	6,8	3042110
GI/EMME 300	2,00	7,8	3042126
GI/EMME 300	2,25	8,7	3042127
GI/EMME 300 - 400	2,50	9,7	3042140
GI/EMME 300 - 400	3,00	11,6	3042158
GI/EMME 300 - 400	3,50	13,6	3042162
GI/EMME 300 - 400 - 600	4,00	15,6	3042172
GI/EMME 400 - 600	4,50	17,5	3042182
GI/EMME 400 - 600	5,00	19,4	3042192
GI/EMME 400 - 600	5,50	21,3	3042202
GI/EMME 600 - 900	6,00	23,3	3042212
GI/EMME 600 - 900	7,00	27,1	3042232
GI/EMME 600 - 900	7,50	29,1	3042242
GI/EMME 900	8,50	33	3042262
GI/EMME 900	9,50	36,8	3042282
GI/EMME 900	10	38,8	3042292
GI/EMME 900	11	42,3	3042312
GI/EMME 900	12,00	46,5	3042322

### Extended head kit

"Standard head" burners can be transformed into "extended head" versions, by using the special kit. The kits available for the various burners, giving the original and the extended lengths, are listed below.

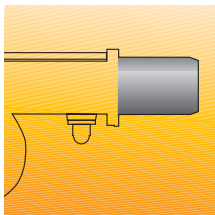

Extended head kit			
Burner	Standard head length (mm)	Extended head length (mm)	Kit code
GI/EMME 300	185	320	3000836
GI/EMME 400	187	320	3010001
GI/EMME 600	187	320	3010002
GI/EMME 900	227	360	3010003



## Sound proofing box

If noise emission needs reducing, sound-proofing boxes are available, as given in the following table:



Sound proofing box			
Burner	Box type	Average noise reduction [dB(A)](*)	Box code
GI/EMME 600 - 900	C1/3	10	3010403

(\*) according to EN 15036-1 standard











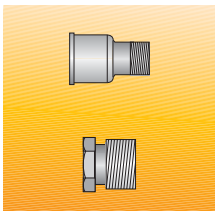





## GAS TRAIN ACCESSORIES



### Adapters

When the diameter of the gas train is different from the set diameter of the burners, an adapter must be fitted between the gas train and the burner.



Adapters			
Burner	Gas train	Dimensions	Adapter code
GI/EMME 300	MBZRDLE 407-410	3/4"  1" 1/2	3000824
	MBZRDLE 412	1" 1/4"  1" 1/2	3010124
GI/EMME 400	MBZRDLE 410	3/4"  1" 1/2	3000824
	MBZRDLE 412	1" 1/4"  1" 1/2	3010124
GI/EMME 600	MBZRDLE 410	3/4"  1" 1/2	3000824
	MBZRDLE 412	1" 1/4"  1" 1/2	3010124
GI/EMME 900	MBZRDLE 420 - CB 50/1	2"  1" 1/2	3000822
	MBZRDLE 410	3/4"  1" 1/2	3000824
GI/EMME 900	MBZRDLE 412	1" 1/4"  2"	3010126
	MBZRDLE 415 - CB 40/1	1" 1/2"  2"	3000843
	CBF 65	DN 65  2" 1/2"  1" 1/2"  2"	3000825



### Seal control kit

To test the valve seals on the gas train, a special "seal control kit" is available.



Seal control kit		
Burner	Gas train	Kit code
GI/EMME 300	MBZRDLE 407 - MBZRDLE 410 - MBZRDLE 412	<b>3010123</b>
	MBZRDLE 415 - CB 40/2 -	<b>3010125</b>
GI/EMME 400	MBZRDLE 410 - MBZRDLE 412	<b>3010123</b>
	MBZRDLE 415 - MBZRDLE 420 CB 40/2 - CB 50/2	<b>3010125</b>
GI/EMME 600	MBZRDLE 410 - MBZRDLE 412	<b>3010123</b>
	MBZRDLE 415 - MBZRDLE 420 CB 40/2 - CB 50/2	<b>3010125</b>
GI/EMME 900	MBZRDLE 412	<b>3010123</b>
	MBZRDLE 415 - MBZRDLE 420 CB 40/2 - CB 50/2 - CBF 65/2	<b>3010125</b>

### Stabiliser spring

Accessory springs are available to vary the pressure range of the gas train stabilisers.

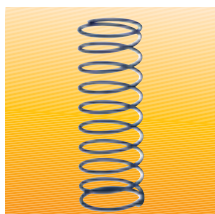

Stabiliser spring		
Gas train	Spring	Spring code
CBF 65/2	Red from 25 to 55 mbar	<b>3010133</b>
CBF 65/2	Black from 60 to 110 mbar	<b>3010135</b>
CBF 65/2	Pink from 90 to 150 mbar	<b>3090456</b>



## SPECIFICATION

A specific index guides your choice of burner from the various models available in the GI/EMME series. Below is a clear and detailed specification description of the product.

### DESIGNATION OF SERIES

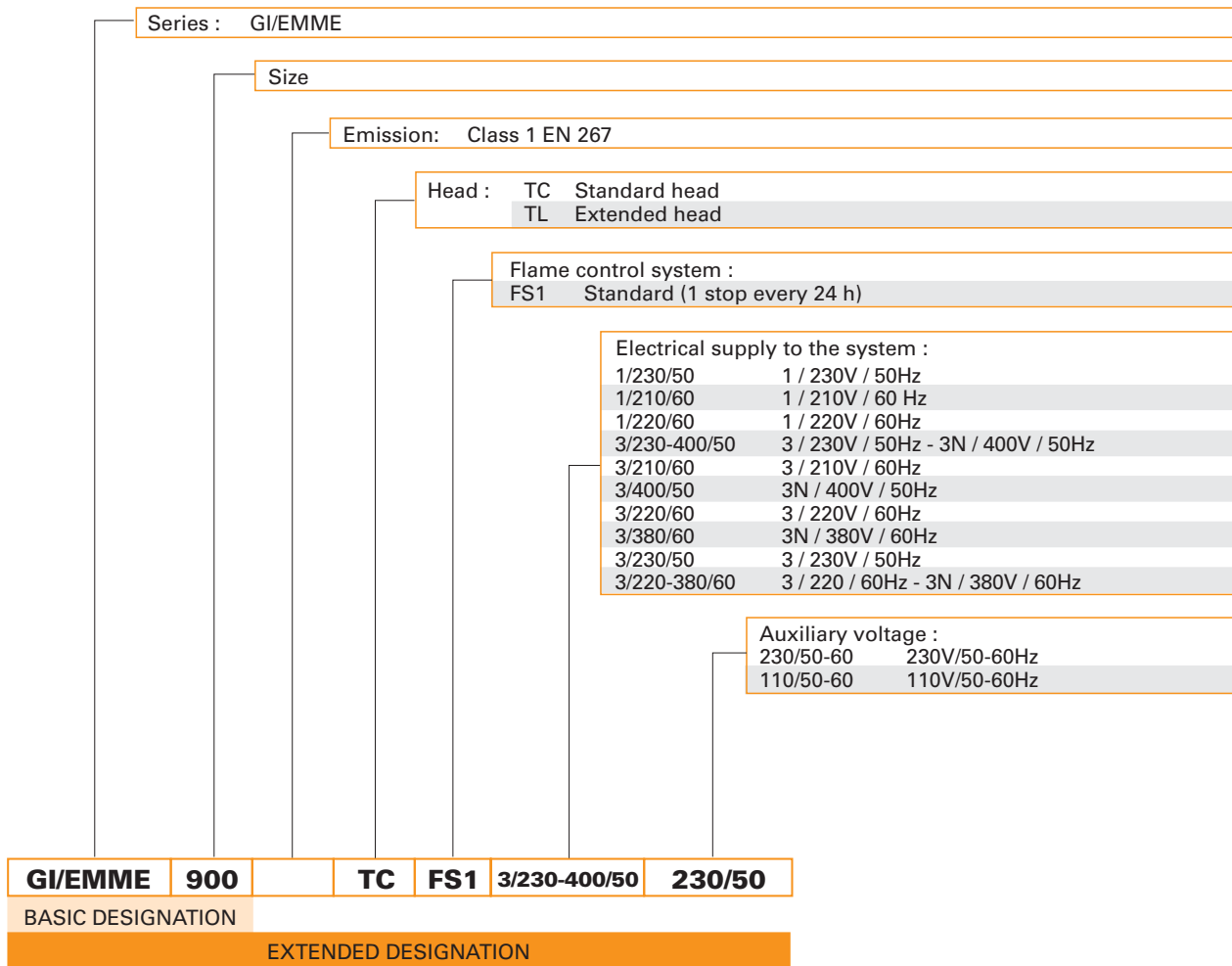

### AVAILABLE BURNER MODELS

GI/EMME 300	TC	FS1	1/220/60	220/60
GI/EMME 300	TC	FS1	1/230/50	230/50
GI/EMME 400	TC	FS1	1/210/60	120/60
GI/EMME 400	TC	FS1	1/230/50	230/50
GI/EMME 400	TC	FS1	3/220-380/60	220/60
GI/EMME 600	TC	FS1	3/210/60	120/60
GI/EMME 600	TC	FS1	3/220-380/60	220/60
GI/EMME 600	TC	FS1	3/230-400/50	230/50

GI/EMME 900	TC	FS1	3/210/60	120/60
GI/EMME 900	TC	FS1	3/220-380/60	220/60
GI/EMME 900	TC	FS1	3/230-400/50	230/50

**Other versions are available on request.**



## ▶ **PRODUCT SPECIFICATION**

### ***Burner:***

Monoblock forced draught dual fuel burner, with two-stage operation, made up of:

- Air suction circuit
- Fan with forward curved blades
- Air damper for setting controlled by a servomotor
- Combustion head, that can be set on the basis of required output
- Maximum gas pressure switch
- Minimum air pressure switch
- Fan electrical motor
- Pump electrical motor
- Gears pump for high pressure fuel supply, fitted with:
  - filter
  - pressure regulator
  - connections for installing a pressure gauge and a a vacuumeter
  - internal by-pass for single pipe installation
- Valve unit with a double oil safety valve on the output circuit
- UV photocell for flame detection
- Flame inspection window
- Slide bars for easier installation and maintenance
- Protection filter against radio interference
- IP 40 protection level.

### ***Gas train:***

Fuel supply line, in the MULTIBLOC configuration (from a diameter of 3/4" until a diameter 2") or COMPOSED configuration (from a diameter of DN 65 until a diameter of DN 100), fitted with:

- Filter
- Stabiliser
- Minimum gas pressure switch
- Safety valve
- Valve seal control (for output > 1200 kW)
- One stage working valve with ignition gas output regulator.

### ***Conforming to:***

- 89/336/EEC directive (electromagnetic compatibility)
- 73/23/EEC directive (low voltage)
- EN 267 (liquid fuel burners)
- EN 676 (gas fuel burners).

### ***Standard equipment:***

- 1 gas train gasket
- 1 flange gasket
- 1 insulating screen
- 2 flexible hoses for connection to the oil supply circuit
- 2 nipples for connection to the pump
- 3 wiring looms fittings for electrical connections
- 8 screws for fixing the burner flange to the boiler
- 1 LPG kit
- Instruction manual for installation, use and maintenance
- Spare parts catalogue.

### ***Available accessories to be ordered separately:***

- Nozzles
- Head extension kit
- Sound proofing box
- Adapters
- Stabiliser spring
- Seal control kit.







RIELLO S.p.A. - Via Ing. Pilade Riello, 5 - 37045 Legnago (VR) Italy  
Tel. ++39.0442630111 - Fax ++39.044221980

Internet: <http://www.rielloburners.com> - E-mail: [info@rielloburners.com](mailto:info@rielloburners.com)

Since the Company is constantly engaged in the production improvement, the aesthetic and dimensional features, the technical data, the equipment and the accessories can be changed.  
This document contains confidential and proprietary information of RIELLO S.p.A.  
Unless authorised, this information shall not be divulged, nor duplicated in whole or in part.

